

Safety Shower

MODEL **4710 GI**

DESCRIPTION	Emergency GI Eye Wash fountain hand & foot operated. Model-4710 GI.
DETAIL COMPONENT SPECIFICATION	
EYE WASH HEAD	Two high-flow sprays, operated at low pressure, which washes the eye and face. Anti-dust cover protects the head from airborne contaminants and automatically opens with the water pressure. (Distance between two eye wash head-165 mm).
EYE WASH BOWL	Highly visible yellow ABS plastic resistant to damage from most acid, alkali and oil. (Size-298mm)
PUSH TO OPEN VALVE	Its connect unit to uninterruptible water supply of 3 gallons.
FOOT PEDAL	For supply and control of water flow in the eye wash head.
BASE PLATE	To hold the shower structure in a stable position. (Size-180mm).

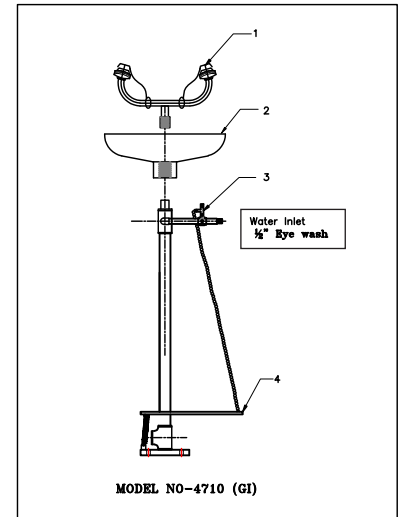

WATER INLET CONNECTION	½" Eye wash	
WATER OUTLET CONNECTION	1 ¼" Tee.	
SUPPLY WATER CONDITION	Supply Water	Drinking Water
	Operating Press.	2 Kgf/cm ² (30 PSI)
	Operating Temp.	Ambient
MATERIAL	1) Pipe	GI
	2) Fitting	GI
	3) Flange	Cast Iron
WEIGHT	7.590 Kg.	
FLOW	10 LPM	
APPROVAL	IS : 10592:1982	

NOTE: All dimensions are in millimeters. Qty/flow of water delivered from eyewash & shower shall be as per IS: 10592:1982

Udyogi Plastics Pvt. Ltd.

294, B. B. Ganguly Street, 2nd Floor, Kolkata - 700 012
 Tel. : +91 33 2225 1470/71/72 ▶ Fax : +91 33 2225 1486
 E-mail : corp@udyogi.net ▶ Website : www.udyogisafety.com

▶ mumbai@udyogi.net ▶ delhi@udyogi.net
 ▶ chennai@udyogi.net ▶ orissa@udyogi.net
 ▶ abd@udyogi.net ▶ noida@udyogi.net